



VNG 802

- Ⓛ **D** Bedienungsanleitung
- Ⓛ **GB** Instruction manual
- Ⓛ **F** Notice d'instruction
- Ⓛ **E** Guia de instrucciones
- Ⓛ **I** Istruzioni per l'uso
- Ⓛ **NL** Gebruiksaanwijzing
- Ⓛ **S** Bruksanvisning
- Ⓛ **N** Bruksanvisning
- Ⓛ **DK** Betjeningsvejledning
- Ⓛ **SF** Käyttöohje
- Ⓛ **PL** Instrukcja obsługi
- Ⓛ **TR** Kullanım El Kitabı





- (D)** Vor der Benutzung überprüfen
- (GB)** Check before use
- (F)** Verifier avant utilisation
- (E)** Antes de la utilizacion compruebe
- (I)** Verificare prima dell'uso
- (NL)** Controleren voor het gebruik
- (S)** Kontrollera före användadet
- (N)** Kontroller før bruk
- (DK)** Kontroller følgende før brug
- (SF)** Tarkista ennen käyttöä
- (PL)** Przed użyciem sprawdź
- (TR)** Kullanmadan önce kontrol edin

- (D)** ÖLSTAND
- (GB)** OIL LEVER
- (F)** NIVEAU HUILE
- (E)** NIVEL DE ACEITE
- (I)** LIVELLO OLIO
- (NL)** OLIEPEIL
- (S)** OLJENIVÅ
- (N)** OLJENIVÅ
- (DK)** OLIESTAND
- (SF)** ÖLJYN MÄÄRÄ
- (PL)** POZIOM OLEJU
- (TR)** YAĞ SEVİYESİ

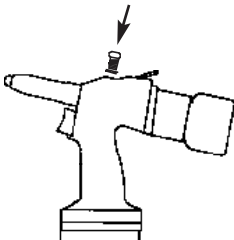

- (D)** BETRIEBSDRUCK
- (GB)** OPERATING PRESSURE
- (F)** PRESSION D'UTILISATION
- (E)** PRESSION DE UTILIZACION
- (I)** PRESSIONE DI UTILIZZO
- (NL)** LUCHTDRUK
- (S)** ARBETSTRYCK
- (N)** ARBEIDSTRYKK
- (DK)** ARBEJDSTRYK
- (SF)** KÄYTTÖPAINE
- (PL)** CIŚNIENIE SPRĘŻONEGO POWIETRZA
- (TR)** ÇALIŞMA BASINCI



- (D)** ZUSTAND GEWINDEDORN
- (GB)** CONDITION OF THE MANDREL
- (F)** ETAT TIGE DE TRACTION
- (E)** ESTADO DEL MANDRIL
- (I)** STATO DELLE ASTA FILETTATA
- (NL)** STAAT VAN DE DRAADSTIFT
- (S)** DRAGDORN KONDITION
- (N)** RENE GJENGETOLK
- (DK)** GEVINDDORN TILSTAND
- (SF)** KIERREKARA ASENTO
- (PL)** STAN TRZPIENA
- (TR)** ÇENELERİN SAPLAMA

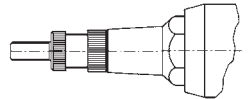



- D** – VERWENDEN SIE ORIGINALTEILE
– NEHMEN SIE KEINE REPARATUREN SELBST VOR
– BEI STÖRUNGEN NEHMEN SIE MIT IHREM HÄNDLER KONTAKT AUF
– ARBEITEN SIE NICHT BEI EINEM BETRIEBSDRUCK VON MEHR ALS 8 BAR
– RICHTEN SIE BEI DER BENUTZUNG DIESES WERKZEUG NIEMALS AUF PERSONEN
– TRAGEN SIE BEI DER BENUTZUNG EINE SCHUTZBRILLE
– TRAGEN SIE BEI DER BENUTZUNG GEHÖRSCHUTZ

- GB** – ONLY USE ORIGINAL PARTS
– DO NOT MAKE REPAIRS YOURSELF
– IN THE EVENT OF PROBLEMS, PLEASE CONTACT YOUR LOCAL DEALER
– DO NOT OPERATE AT A PRESSURE OF MORE THAN 8 BAR
– NEVER POINT THIS TOOL TOWARDS ANOTHER PERSON
– WEAR SAFETY GLASSES WHEN USING THIS TOOL
– WEAR EAR PROTECTORS WHEN USING THIS MACHINE

- F** – N'UTILISER QUE DES PIÈCES D'ORIGINES
– NE PAS EFFECTUER DE RÉPARATIONS VOUS MÊME
– EN CAS D'ANOMALIE, VEUILLEZ CONTACTER VOTRE DISTRIBUTEUR
– NE PAS UTILISER UNE PRESSION SUPÉRIEURE À 8 BAR
– NE DIRIGÉ JAMAIS CET OUTIL VERS UNE PERSONNE
– PORTEZ DES LUNETTES DE PROTECTION LORS DE L'UTILISATION
– PORTEZ UN CASQUE D'ISOLATION PHONIQUE PENDANT L'UTILISATION

- E** – UTILICE UNICAMENTE PIEZAS DE ORIGEN
– NO EFECTUE REPARACIONES USTED MISMO
– EN CASO DE ANOMALIA, PONGASE EN CONTACTO CON SU DISTRIBUIDO
– NO USE UNA PRESION DE UTILIZACION SUPERIOR A 8 BARES
– NO DIRIJA NUNCA ESTA HERRAMIENTA HACIA UNA PERSONA
– LLEVE GAFAS DE PROTECCION DURANTE LA UTILIZACION
– LLEVE UN CASCO DE AISLAMIENTO FONICO DURANTE LA UTILIZACION

- I** – UTILIZZARE UNICAMENTE RICAMBII ORIGINALI
– NON PUNTARE MAI L'UTENSILE CONTRO TERZI
– IN CASO DI ANOMALIA CONSULTARE IL VOSTRO DISTRIBUTORE
– NON USARE MAI UNA PRESSIONE D'UTILIZZO SUPERIORE A 8 BAR
– NON PUNTARE MAI LO STRUMENTO CONTRO UNA PERSONA
– METTERE OCCHIALI DI PROTEZIONE DURANTE L'UTILIZZO

- NL** – ALLEEN ORGINELE ONDERDELEN GEBRUIKEN
– ZELF GEEN REPARATIES UITVOEREN
– BIJ STORINGEN CONTACT OPNEMEN MET UW LEVERANCIER
– GEEN DRUK HOGER DAN 8 BAR GEBRUIKEN
– DIT GEREEDSCHAP NOOIT OP IEMAND RICHTEN
– TIJDEN GEBRUIK GEHOOR- EN GEZICHTSBE-SCHERMING DRAGEN

- S** – ANVÄND ENDAST ORIGINALDELAR
– REPARERA EJ SJÄLV
– VID EV. DRIFTSTÖRNINGAR KONTAKTA DIN LEVERANTÖR
– ANVÄND EJ HÖGRE TRYCK ÄN 8 BAR
– RIKTA ALDRIG VERKTÖGET MOT ANDRA PERSONER
– ANVÄND SKYDDSGLASÖGON
– ANVÄND HÖRSELKYDD

- N** – KONTROLLER TRYKKLUFTSLANGEN OG KOPLINGEN FØR BRUK
– ARBEIDSTRYKKET MÅ IKKE OVERSTIGE 8 BAR
– KOBLE FRA TRYKKLUFTSLANGEN FØR DU UTFØRER NOE ARBEIDE PÅ SELVE VERKTØYET
– VED PROBLEMER, KONTAKT SELGER
– SIKT ALDRI MED VERKTØYET PÅ ANDRE MENNESKER
– BRUK VERNEBRILLER OG VED BEHOV HØRSELVERN
– BRUK VERKTØYET KUN FOR DET RIKTIGE FORMÅLET

- DK** – ANVEND KUN ORIGINALDELE
– REPARER ALDRIG SELV VÆRKTØJET
– KONTAKT DERES LEVERANDØR VED VÆRKTØJSPROBLEMER
– VÆRKTØJET MÅ IKKE BRUGES VED MERE END 8 BAR TRYK
– PEG ALDRIG VÆRKTØJET MOD EN ANDEN PERSON
– BÆR ALTID BESKYTTELSBRILLER UNDER ARBEJDET
– BÆR ALTID HØREVÆRN UNDER ARBEJDET

- SF** – KÄYTTÄ VAIN ALKUPERÄISIÄ VARAOSIA
– ÄLÄ TEE ITSE KORJAUSTÖITÄ
– OTA ONGELMATAPAUSSISSA YHTEYTTÄ LAITTEEN MYINEESEN LIIKKEESEEN
– ÄLÄ KÄYTTÄ YLI 8 BARIN PAINETTA
– LAITTEELLA EI SAA OSOITTA MUITA IHMISIÄ KOHTI
– KÄYTTÄ SUOJALASEJA JA MAHDOLLISESTI MYÖS KUULOSUOJAIMIA

- PL** – STOSOWAĆ WYŁĄCZNIE ORIGINALNE CZĘŚCI ZAMIENNE
– NIE PODEJMOWAĆ SAMODZIELNYCH REPARATUR
– W PRZYPADKU USTEREK SKONTAKTOWAĆ SIĘ Z PUNKTEM SPRZEDAŻY
– NIE STOSOWAĆ SPRĘŻONEGO POWIETRZA POWYŻEJ 8 BAR
– NIGDY NIE KIEROWAĆ NARZĘDZIA W STRONĘ OSÓB
– PODCZAS PRACY NOSIĆ OKULARY OCHRONNE
– STOSOWAĆ ŚRODKI OCHRONY SŁUCHU

- TR** – SADECE ORJİNAL PARÇA KULLANIN
– KENDİNİZ TAMİRAT YAPMAYIN
– SORUN HALİNDE BÖLGE BAYİNİZLE TEMAS KURUN
– 8 BARDAN YÜKSEK BASINÇTA ÇALIŞTIRMAYINIZ
– BU ALETİ BAŞKA BİR ŞAHSA DOĞRU TUTMAYINIZ
– BU ALETİ KULLANIRKEN EMNİYET GÖZLÜĞÜ TAKINIZ
– BU MAKİNEYİ KULLANIRKENKULAK KORUYUCUSU KULLANIN

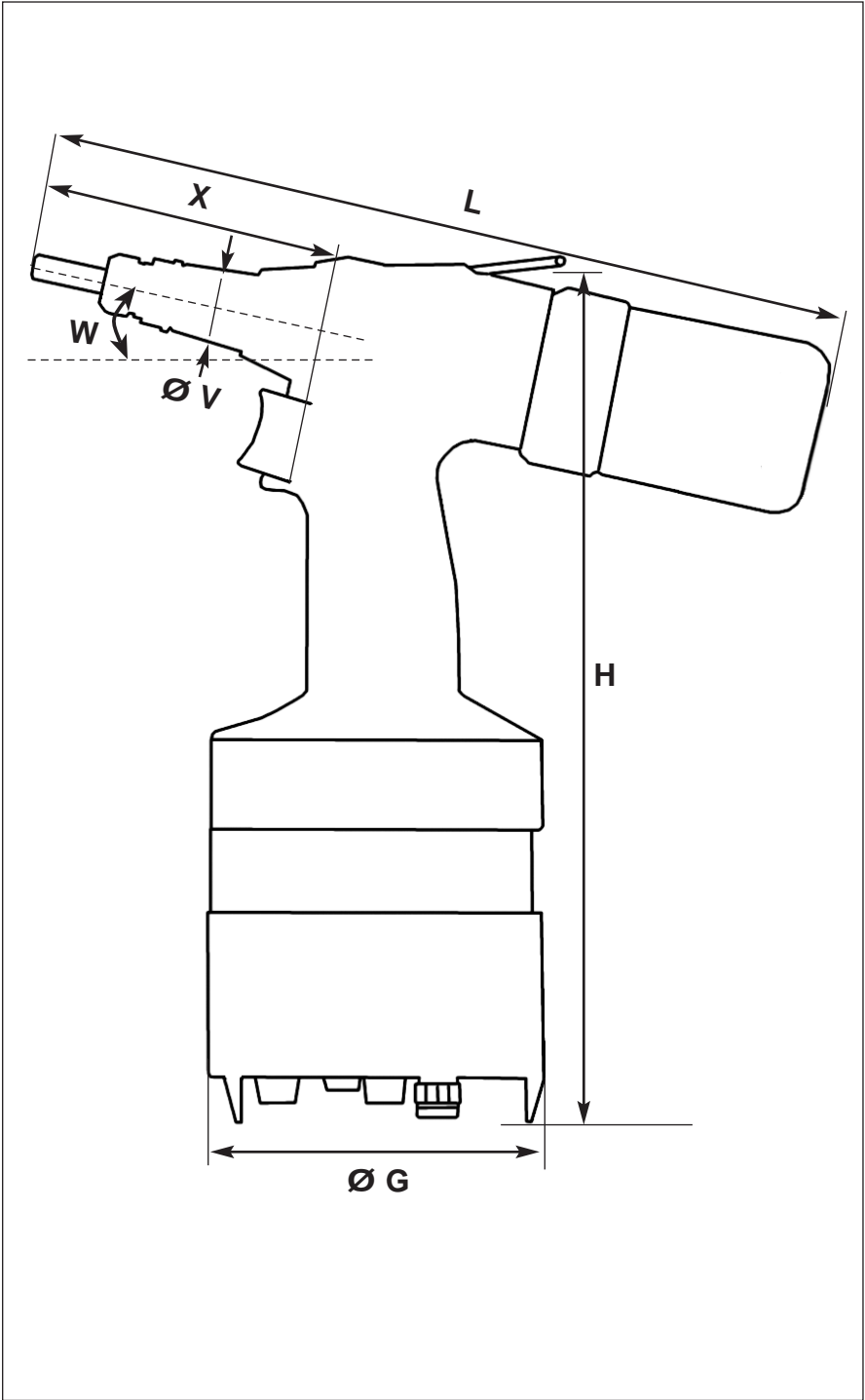



VNG 802



VNG 802



5 – 7 bar

X

58



29.000 N

Ø G

90

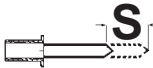

max. 7 mm



M 4 – M 10

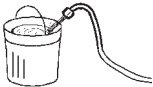

7,5 l



M 4 – M 8



2,7 kg

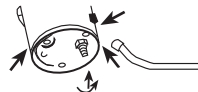

L

280 mm

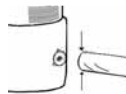

1/4 "

H

300 mm



4,5 E/50 C



12°



70 dB(A)

Ø V

26,0



0,64 m/s²



Automatisches Auffädeln der Blindnietmutter

Automatisches Auffädeln durch leichten Druck der Blindnietmutter gegen den Gewindedorn (Drücken = Auffädeln/Rechtslauf)

Automatic feeding of blind rivet nuts

Automatic feeding by pressing the rivet nut slightly against the mandrel (press = mandrel turns right)

Vissage automatique de l'écrou à sertir

Vissage automatique de l'écrou par simple pression de celui-ci sur la tige de traction (pousser sur la tige = vissage)

**Drücken =
Auffädeln/Rechtslauf**

**Press = mandrel
turns right**

**Pousser sur la tige =
vissage**





Einstellbare Abfädelzeit

Messing-Rändelrad zur Einstellung der Abfädelzeit
(Herausdrehen = Abfädelzeit verkürzen)

Spin off time

Turn knurled brass knob for adjustment off spin off time
(unscrew counter clock wise = decrease spin off time)

Temporisation du dévissage

Molette en laiton permettant le réglage de la temporisation du dévissage (dévisser = raccourcissement de la temporisation)

**Herausdrehen =
Abfädelzeit ver-
kürzen**

**Unscrew =
decrease
spin off time**

**Dévisser =
raccourcissement
de la tempori-
sation**





Einstellbare Auffädelgeschwindigkeit

Messing-Rändelrad zur Einstellung der Auffädelgeschwindigkeit
(Herausdrehen = Auffädelgeschwindigkeit erhöhen)

Adjustable speed for feeding

Turn knurled brass knob for adjustment off feeding speed (revolutions of the mandrel) (unscrew counter clock wise = increase speed)

Réglage de la vitesse de dévissage

Molette en laiton permettant le réglage de la vitesse de dévissage
(dévisser = augmentation de la vitesse)



(Herausdrehen =
Auffädelgeschwin-
digkeit erhöhen)

(unscrew =
increase speed)

(dévisser =
augmentation
de la vitesse)



Manuelle Linkslaufauslösung

Messingknopf zur Auslösung des manuellen Linkslaufes (gedrückt halten = Linkslauf/Abfädeln)

Manual spin off

Brass push button for manual spin off
(hold push button down = spin off)

Dévisage manuel

Bouton en laiton pour le déclenchement manuel du dévissage
(maintenir enfoncé = dévissage)

gedrückt halten =
Linkslauf/Abfädeln

hold push button
down =
spin off

maintenir enfoncé =
dévisage



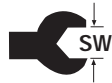

SW 20
SW 24

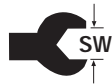
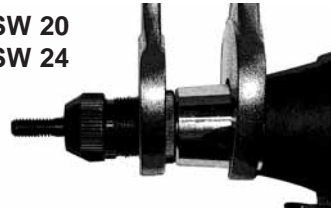

SW 24

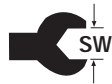

SW 10
SW 12

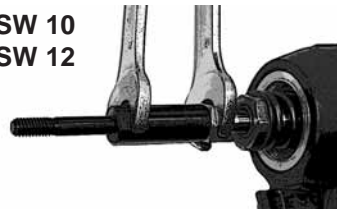

SW 10
SW 12

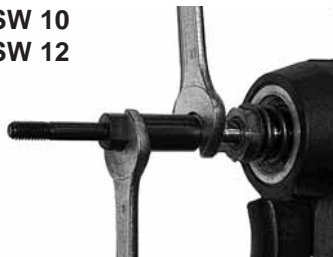

SW 12

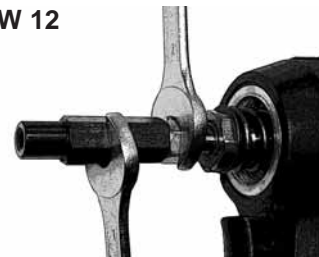

SW 24



SW 24

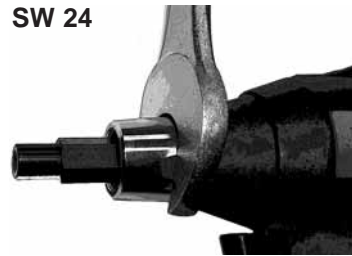

SW 20
SW 24



SW 20
SW 24



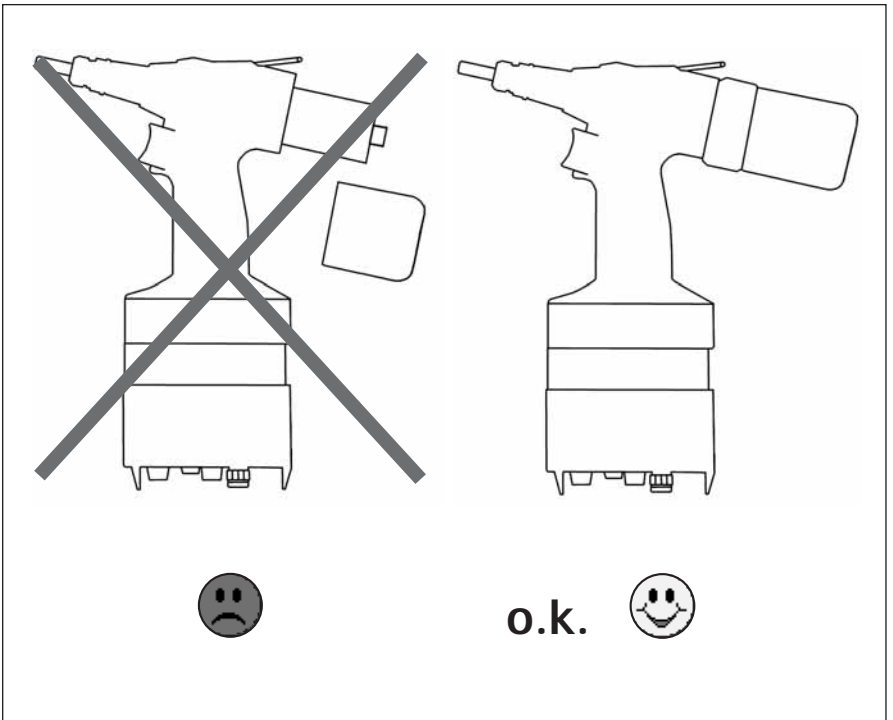
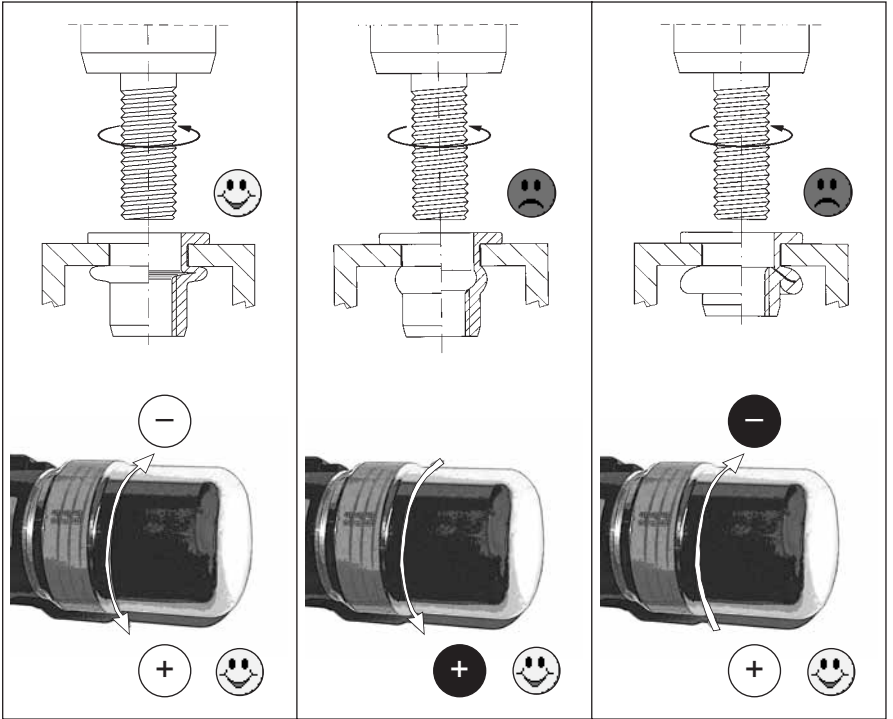

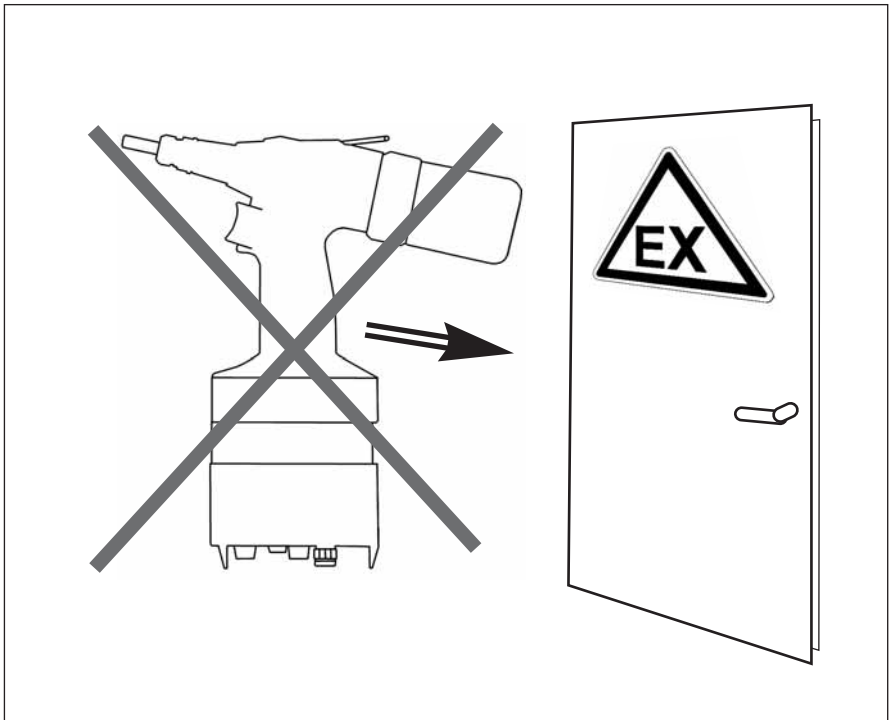
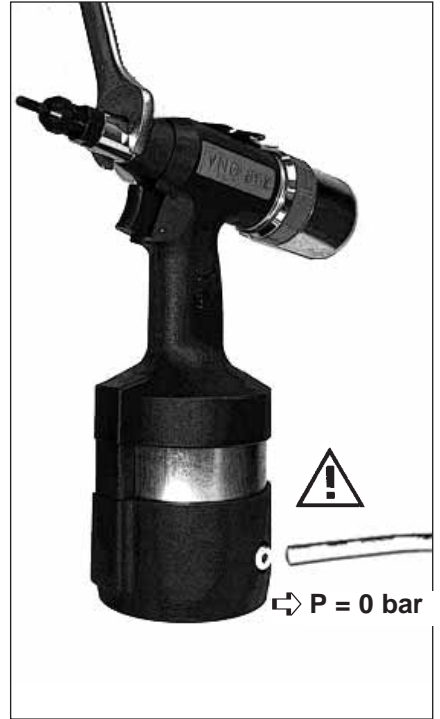
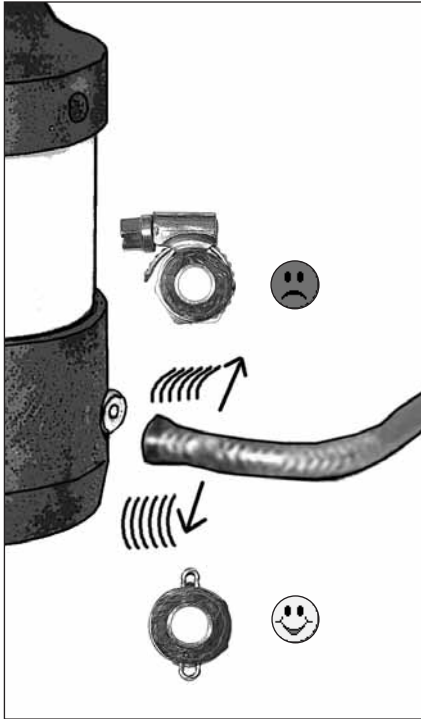

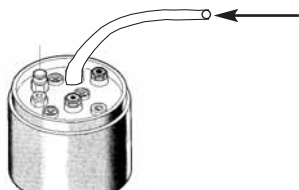

- (D) TROCKENE LUFT
- (GB) DRY AIR
- (F) AIR SEC
- (E) AIRE SECO
- (I) ARIA SECCA
- (NL) DROGE LUCHT
- (S) TORR LUFT
- (N) TØRR LUFT
- (DK) TØR LUFT
- (SF) KUIVAA ILMAA
- (PL) SUCHE, SPR
- (TR) KURU HAVA

ONE POWIETRZE

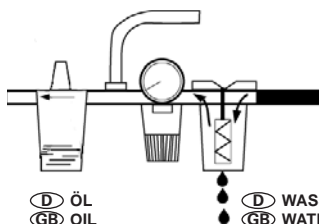

- (D) ÖL
- (GB) OIL
- (F) HUILE
- (E) ACIETE
- (I) OLIO
- (NL) OLIE
- (S) OLJA
- (N) OLJE
- (DK) OLIE
- (SF) ÖLJYÄ
- (PL) OLEJ
- (TR) YAĞ

- (D) WASSER
- (GB) WATER
- (F) EAU
- (E) AQUA
- (I) AQUA
- (NL) WATER
- (S) VANN
- (N) VANN
- (DK) VAND
- (SF) VESI
- (PL) WODA
- (TR) SU

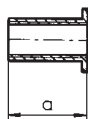
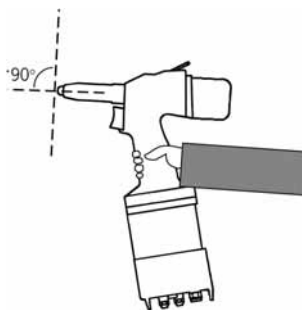

$$a - b = s$$

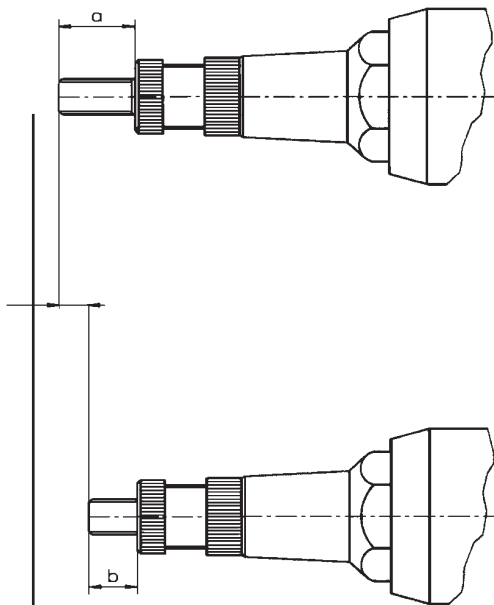

VNG 802

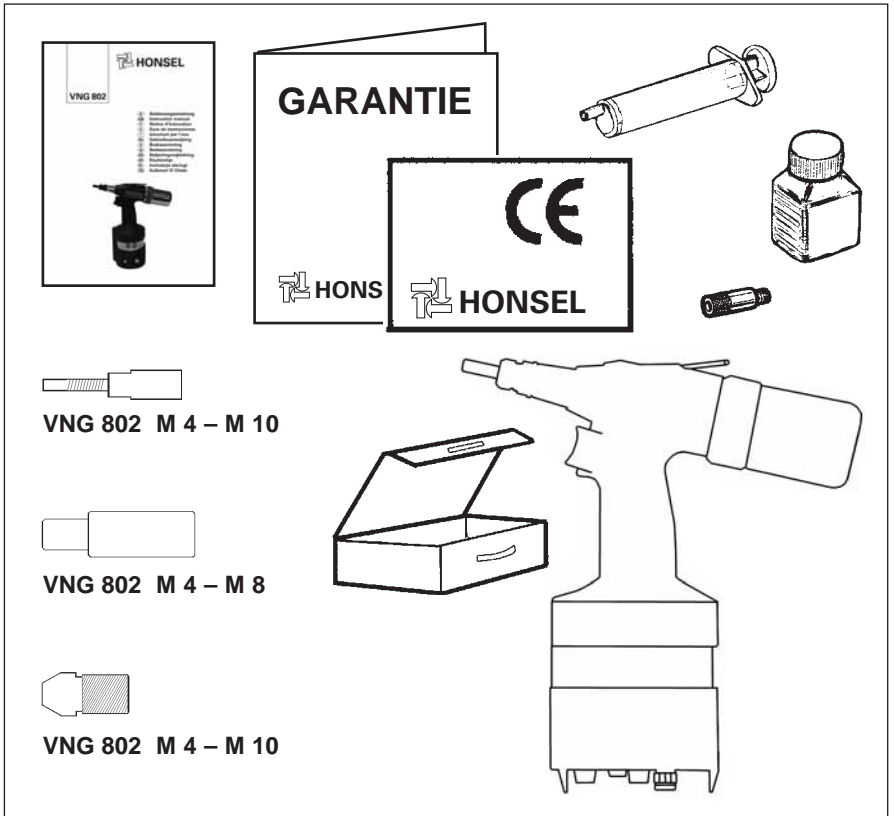
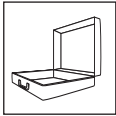
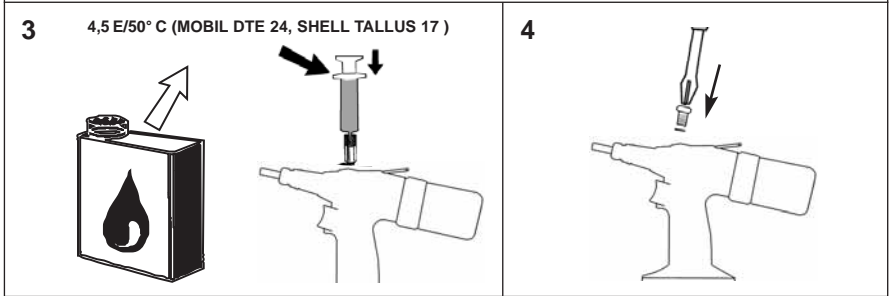
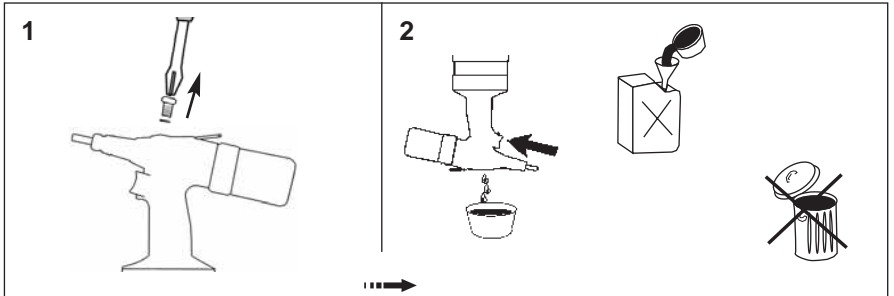

VNG 802

Deutschland:

VVG

Befestigungstechnik
GmbH & Co.
Haberstraße 29
24537 Neumünster
Postfach 2752
24517 Neumünster
Tel. +49 (0) 43 21/96 7171
Fax +49 (0) 43 21/96 7196

Frankreich:

Alfred Honsel s.a.r.l.

20, rue du Lhotaud
Boîte Postale 1
F-25560 Frasne
Tel. +33 (3) 381498946
Fax +33 (3) 381498947

VVG France s.a.r.l.

20, rue du Lhotaud
Boîte Postale 1
F-25560 Frasne
Tel. +33 (3) 381498900
Fax +33 (3) 381498699

Belgien:

Combori N.V.

Blancefloerlaan 181
B-2050 Antwerpen
Tel. +32 (0) 3/2101211
Fax +32 (0) 3/2195804

Dänemark:

OJD Trading ApS

Lerbaekvej 16 + 18
DK-2680 Solroed Strand
Tel. (+ 45) 53 14 14 28
Fax (+ 45) 53 14 64 78
e-mail: ojd@ojd.dk

Finnland:

Oy Mercantile AB

Mercantile Pultti
Hakkilankaari 2
SF-01380 Vantaa
Tel. + 358 9 34 501
Fax + 358 9 873 3662

Niederlande:

Borstlap B.V.

Postbus 50 34
NL-5004 EA Tilburg
Tel. +31 (0) 13/5941234
Fax +31 (0) 13/5941212

Norwegen:

Tingstad AS

Stalfjæra 17
Kalbakken
Postboks 83
N-0902 Oslo
Tel. +47/22169400
Fax +47/22164583

Italien:

Unicom SRL

Rappresentanze
Industriali
Via Arona, 37
I-10145 Torino
Tel. +39 (0) 117716090
Fax +39 (0) 117716127

Polen:

PHU Marsel BIS

Marek Chlebosz
UL. Soldka 16 d
PL-80299 Gdansk
Tel. +48 (0) 58-5500700
Fax +48 (0) 58-5500700

Schweiz:

Airproduct AG

Bremgartenstrasse 31
CH-8966 Oberwil-Lieli
Tel. +41 (0) 566339633
Fax +41 (0) 566339638

Türkei:

Günmak

Kompresör ve Makina
Sanayi ve Ticaret A.S.
Perpa Ticaret Merkezi
Kat. 9
No. 1354
TR-80270 Okmeydanı-
İstanbul
Tel. +90 (0) 2122215510
Fax +90 (0) 2122215509

Südafrika:

Hyper Pneumatics

Postbox 10499
Linton Grange
ZA-6015 Port Elizabeth
Tel. +27 (0) 413604686
Fax +27 (0) 413606255

USA:

Global Techsol

2400 E. Main Street
Suite 103 # 311
USA-St. Charles
IL 60175
Tel. +1 (630) 2581879
Fax +1 (630) 5131861



Honsel Umformtechnik GmbH

Westicker Straße 46 - 52
58730 Fröndenberg/ Ruhr
Deutschland
fon +49 (0) 2373 755 0
fax +49 (0) 2373 755 600
info@honsel.de
www.honsel.de